

0221560

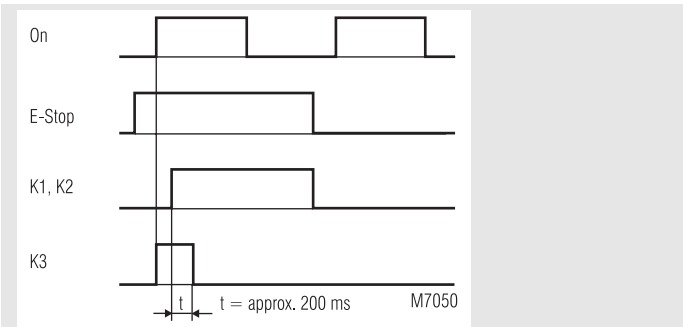

- According to EC Directive for machines 98/37/EG
- According to IEC/EN 60204-1
- Safety category 4 according to EN 954-1
- Output: 3 NO, 1 NC contacts for AC 400 V
- Optionally gold-plated contacts to switch small loads (input for PLC)
- 1-channel or 2-channel connection
- LED displays for channels 1 and 2
- Feedback circuit X3 - X4 for monitoring external contactors
- Optionally with protective separation to IEC/EN 61 140, IEC/EN 69 947-1
- Removable terminal strips
- Overvoltage and short circuit protection
- Width 100 mm

Function diagram



Approvals and marking



* see variants

Application

- Protection of people and machines
- Emergency-stop circuits on machines
 - Monitoring of safety gates

Indication

- LED power supply: on when operating voltage present
 LED S12 / K2: on when supply on relay K2
 LED S22 / K3: on when supply on relay K3

Notes

The PE terminal permits operation of the device in IT systems with insulation monitoring and also serves as a reference point for testing the control voltage. The internal short-circuit protection will be bridged on DC devices, if the protective ground is connected to terminal PE. One or more extension modules BN 3081 or external contactors with positively-driven contacts may be used to multiply the number of contacts of the emergency-stop module BN 5983.

ATTENTION - AUTOMATIC START!



According to IEC/EN 60 204-1 part 9.2.5.4.2 it is not allowed to restart automatically after emergency stop. Therefore the machine control has to disable the automatic start after emergency stop.

Block diagram BN 5983.53

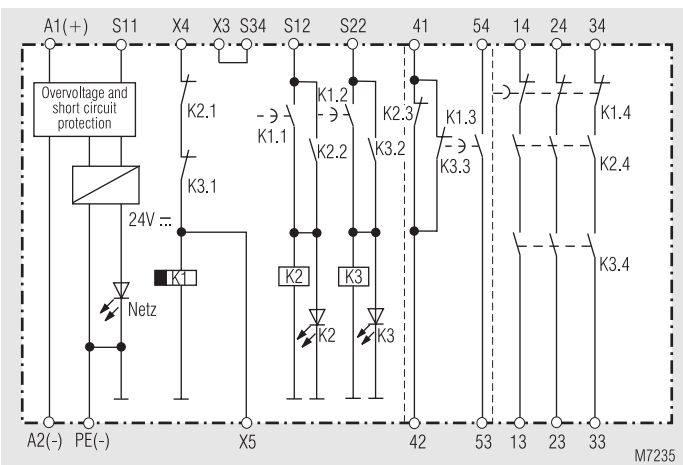

Circuit diagrams

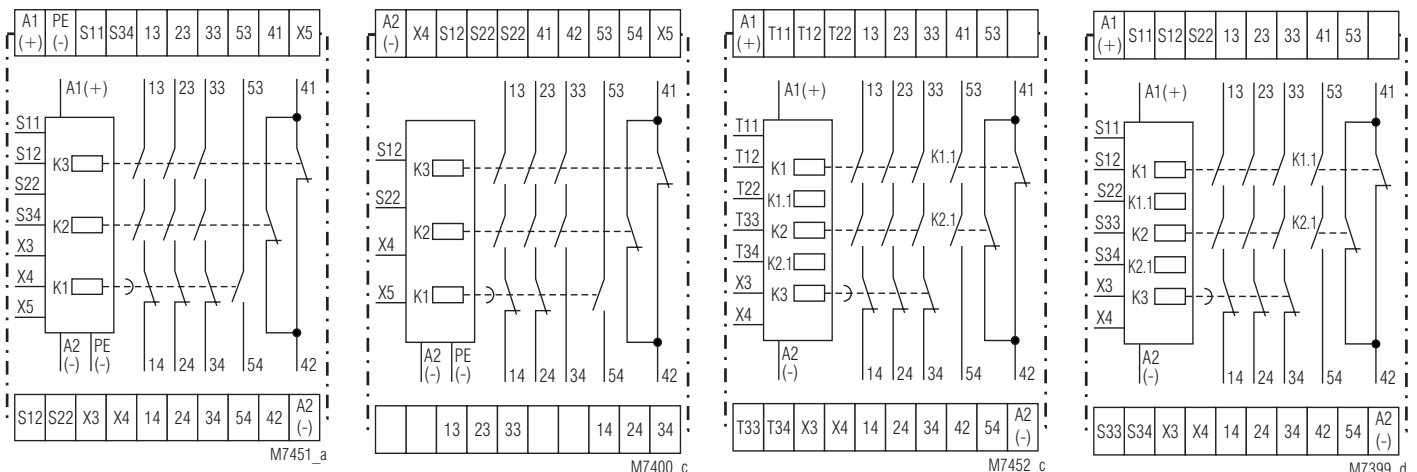

BN 5983.53, _/101, _/104, _/107, BN 5983.53/110, _/200

BN 5983.53/106

BN 5983.54/202

BN 5983.54

Technical data

Input

Nominal voltage U_N:	AC 24, 48, 110, 127, 230, 240 V DC 24 V
Voltage range:	AC 0,8 ... 1,1 U_N
at 10 % residual ripple:	DC 0,9 ... 1,2 U_N
at 48 % residual ripple:	DC 0,8 ... 1,1 U_N
Nominal consumption:	5 VA \pm 30 %
Nominal frequency:	50 / 60 Hz
Control voltage S11:	DC 24 V
Control current:	max. DC 100 mA
Minimum voltage at terminals S12, S22:	DC 21 V with activated device

Output

Contacts

BN 5983.53:	3 NO, 1 NC contacts 1 delay-release NO contact (K1.3) The NO contacts 13...33 / 14...34 are safety contacts. ATTENTION! The NC contact 41-42 and the NO contact 53-54 can only be used for monitoring. 35 ms
-------------	---

Operate time:

Release time

opening in secondary circuit (S12-S22):

30 ms \pm 25 %

opening in supply circuit:

100 ms \pm 50 %

Release delay of K1:

approx. 200 ms

Contact type:

Relay, positively-driven

Nominal output voltage:

AC 400 V / DC 230 V

Thermal current I_{th} :

see continuous current limit curve (max. 10 A in one contact path)

Switching capacity

to AC 15:

5 A / AC 230 V IEC/EN 60 947-5-1
for NO contacts

2 A / AC 230 V IEC/EN 60 947-5-1
for NC contacts

to DC 13:

4 A / DC 24 V IEC/EN 60 947-5-1
for NO contacts

4 A / DC 24 V IEC/EN 60 947-5-1
for NC contacts

NO contacts

2 contacts in series:

10 A / 24 V > 10⁵
ON: 0,4 s, OFF: 9,6 s

Electrical life

to AC 15 at 2 A, AC 230 V: 10⁵ switching cycles IEC/EN 60 947-5-1
to DC 13 at 2 A, AC 230 V: > 240 x 10³ switching cycles

Permissible operating frequency:

6 000 switching cycles / h

Short circuit strength

max. fuse rating: 10 A gL IEC/EN 60 947-5-1

max. line circuit breaker: C 10 A

Mechanical life:

10 x 10⁶ switching cycles

General data

Operating mode:	Continuous operation
Temperature range:	- 15 ... + 55°C at max. 90 % humidity

Clearance and creepage distances

overvoltage category / contamination level: 4 kV / 2 IEC 60 664-1

EMC

Electrostatic discharge: 8 kV (air) IEC/EN 61 000-4-2

HF irradiation: 10 V / m IEC/EN 61 000-4-3

Fast transients: 2 kV IEC/EN 61 000-4-4

Surge voltages between

wires for power supply: 1 kV IEC/EN 61 000-4-5

between wire and ground: 4 kV IEC/EN 61 000-4-5

Interference suppression: Limit value class B EN 55 011

Degree of protection: Housing: IP 40 IEC/EN 60 529

Terminals: IP 20 IEC/EN 60 529

Technical data

Housing:	Thermoplastic with V0 behaviour according to UL subject 94
Vibration resistance:	Amplitude 0,35 mm IEC/EN 60 068-2-6 frequency: 10 ... 55 Hz
Climate resistance:	15 / 055 / 04 IEC/EN 60 068-1
Terminal designation:	EN 50 005
Wire connection:	2 x 2,5 mm ² solid or 2 x 1,5 mm ² stranded ferruled DIN 46 228-1/-2/-3/-4
Wire fixing:	Flat terminals with self-lifting clamping piece IEC/EN 60 999-1 Removable terminal strip
Mounting:	DIN rail IEC/EN 60 715
Weight:	840 g

Dimensions

Width x height x depth: 100 x 74 x 121 mm

Standard type

BN 5983.53 DC 24 V		
Article number:	0032155	stock item
• Output:	3 NO, 1 NC contacts	
• Nominal voltage U_N :	DC 24 V	
• Width:	100 mm	

Variants

BN 5983.53/60: with CSA approval

BN 5983.53/61: with UL approval (Canada/USA)

BN 5983.53/101: Release delay of K1 approx. 800 ms

BN 5983.53/104:

For switching small loads of 1 mA ... 7 VA or 1 mW ... 7 W in the ranges 0,1 ... 60 V and 1 ... 300 mA.

The device is also suitable for switching the maximum switching current. However, this will burn off the gold plating of the contacts, so that switching of small loads is no longer possible afterwards.

BN 5983.53/106:

Protective separation of control and load circuits, contacts 13÷14, 23÷24 and 33÷34 according to VDE 0106 part 101 4 kV / 2 referred to overvoltage category II with basic insulation to IEC 60 664-1 of 2,5 kV / 2. Contacts 41÷42 and 53÷54 to control circuit 2 kV/2 to IEC 60 664-1.

BN 5983.53/107:

This version has the device characteristics of BN 5983.53/104 and protective separation of control and load circuits of IEC/EN 611 140, IEC 60 947-1 4 kV / 2 referred to overvoltage category II with basic insulation to IEC 60 664-1 of 2,5 kV / 2.

BN 5983.53/110:

To avoid latching problems in the case of short voltage drops K2 and K3 are switched definitely off before reset.

BN 5983.53/200:

Redundant switching off with device diversity. Device diversity means that safety relays from different production batches or from different manufacturers are used.

BN 5983.53/202:

Special terminal arrangement (see circuit diagrams).

BN 5983.54:

This version differs from the standard device BN 5983.53 only with respect to the contact complement. The additional signalling contacts K1.1 and K2.1 are available via the terminals 53-54 instead of the delay-release NO contact.

Please note that these contacts must not be used for positive opening.

Ordering example for Variants

BN 5983 .53 / _ _ _ AC 230 V 50/60 Hz

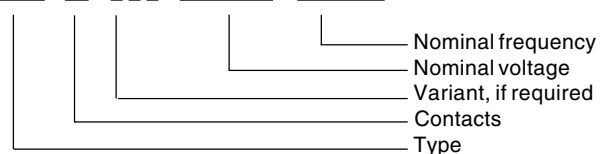

Characteristics

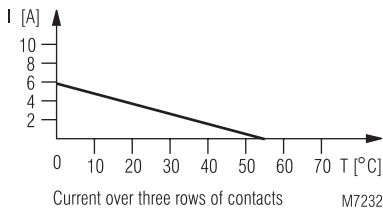
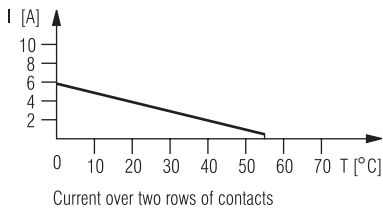
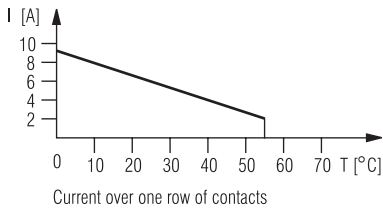

electric life DC13 24V DC / t_{on} 0,4s; t_{off} 9,6s
2 contacts in series

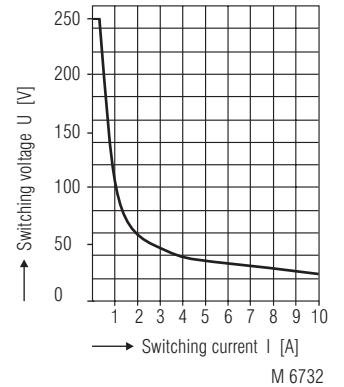
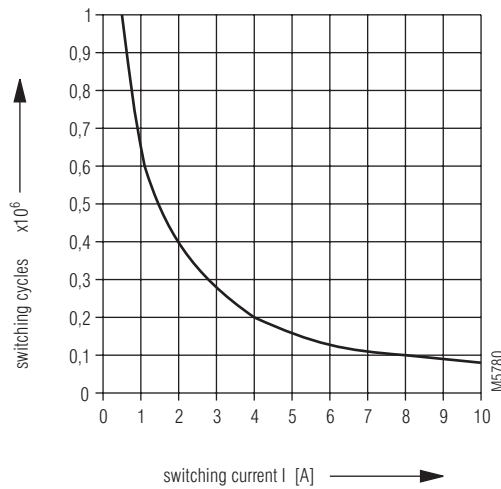

Continuous current limit curves as a function of ambient temperature

Contact service life

Limit curve for arc-free operation with resistive load

Application examples

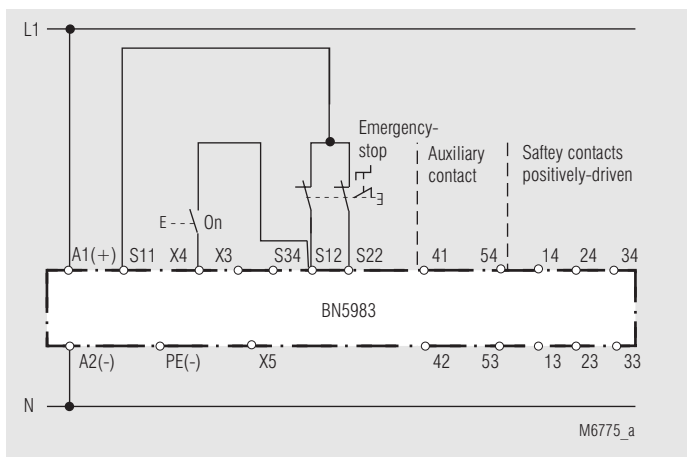

Two-channel emergency stop circuit

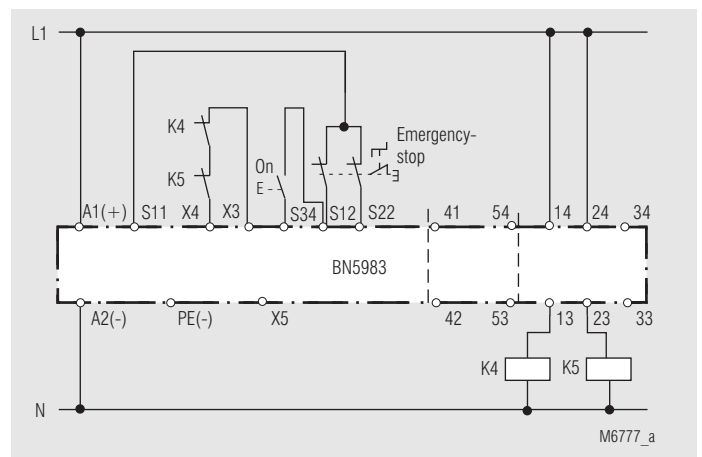

Contact reinforcement by external contactors, 2-channel.
The output contacts can be reinforced by external contactors with positively-driven contacts for switching currents > 10 A. Functioning of the external contactors is monitored by looping the NC contacts into the closing circuit (terminals X3 - X4).

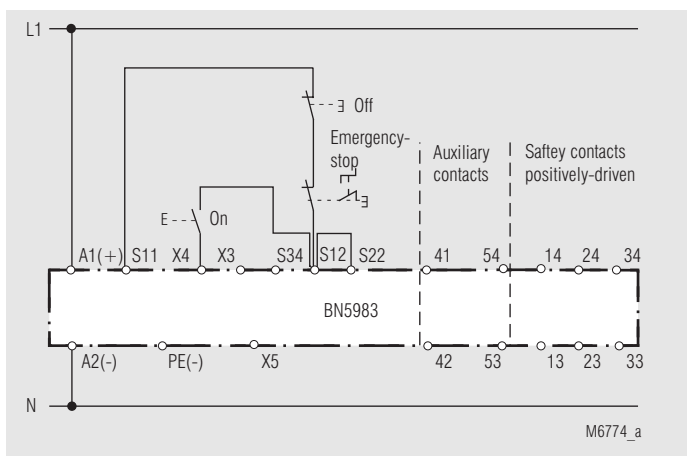

One-channel emergency-stop circuit. This circuit does not have any redundancy in the emergency-stop control circuit

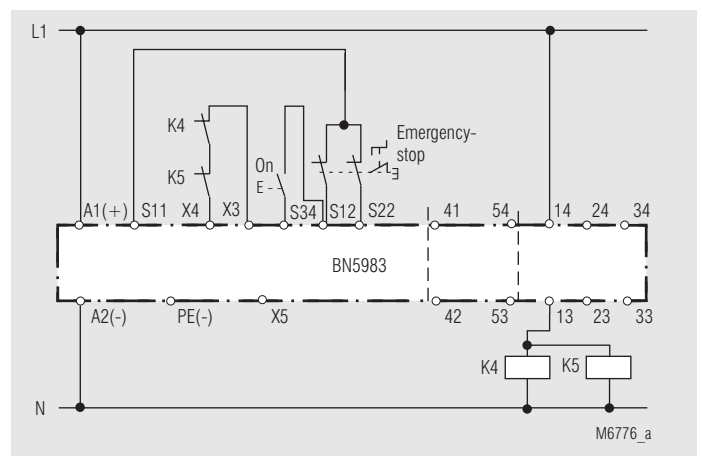

Contact reinforcement by external contactors with reduced safety level

Application examples

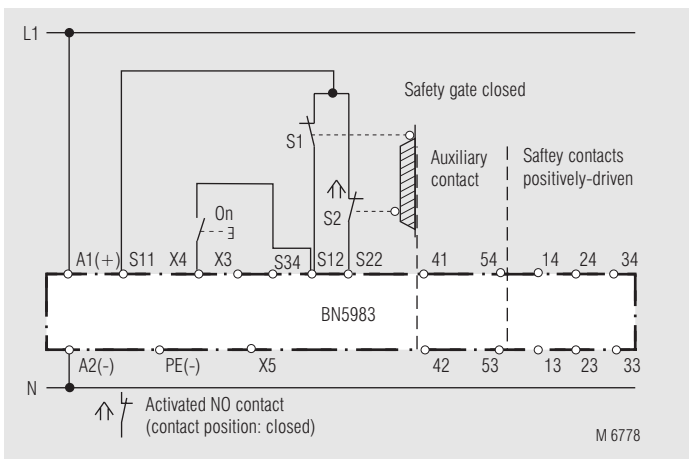

M 6778

Two-channel monitoring of a safety gate

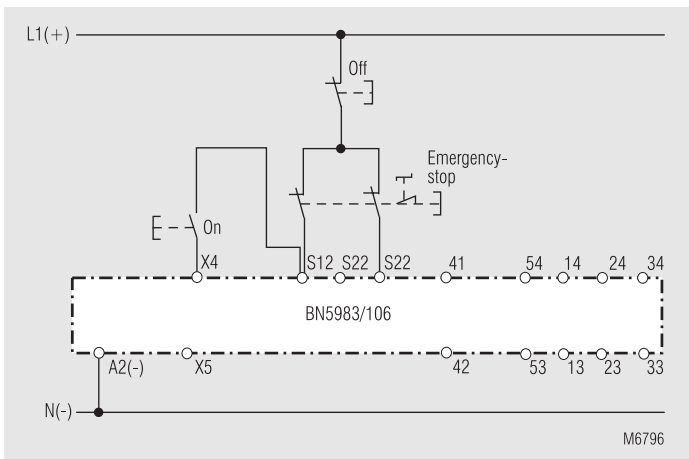

M6796

Two-channel emergency stop circuit with BN 5983/106.

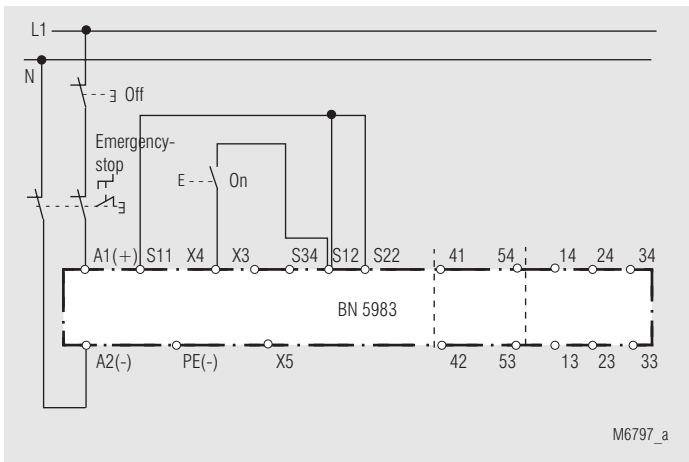

M6797_a

Picture M 6797:

Two-pole emergency-stop circuit with emergency stop control device in supply circuit.

Application for long emergency stop loops where the control voltage drops below the minimum voltage of 21 V.

Attention:

Single faults (e.g. line faults at the emergency stop control device) are not detected with this external circuit configuration